



## 拨片套装 (单拨片版) 快速指南

### 1.0 配件清单

- 拨片组垫高铝柱 x4 (3.1x5x3mm)
- 拨片组垫高铝柱 x4 (3.1x5x5mm)
- 沉头螺钉M3-6 x 6
- 沉头螺钉M3-8 x 10
- 沉头螺钉M3-12 x 6
- 六角扳手 x2 (2mm/2.5mm)



碳纤维换挡拨片板



铝制换挡拨片板



塑料换挡拨片板



拨片延长件

### 2.0 安装

- 2.1 ① 塑料换挡拨片与碳纤维换挡拨片板: 使用沉头螺钉M3-8固定
- ② 铝制换挡拨片板: 使用沉头螺钉M3-6固定

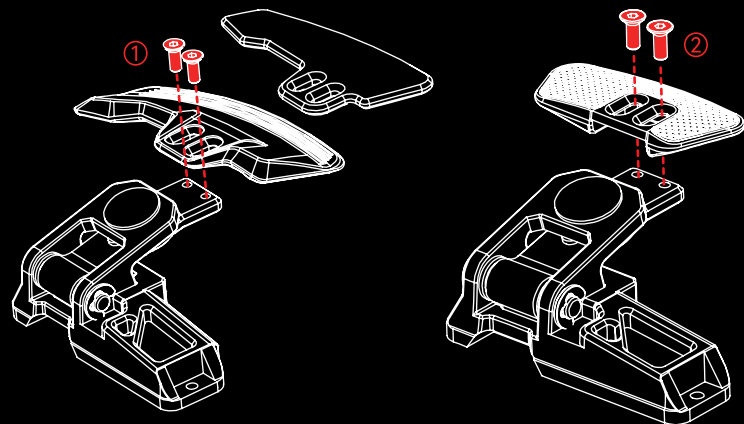

2.2 根据所需要距离, 选择3mm或者5mm高度的垫高铝柱, 如图用沉头螺钉M3-12固定在拨片上 (沉头孔面朝上)

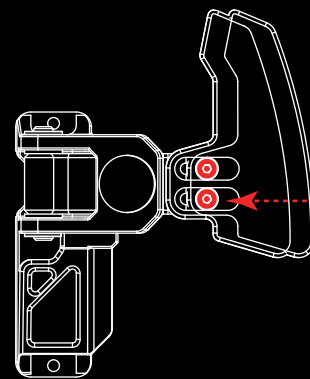
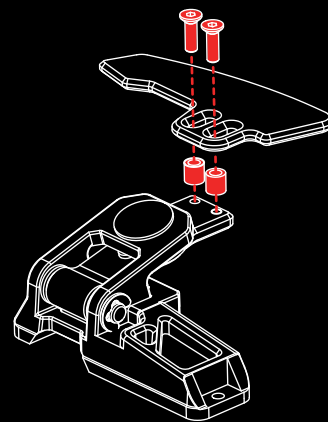

2.3 通过调整两颗沉头螺钉M3, 调整拨片板的距离

2.4 用两颗沉头螺钉M3-8固定延长件到拨片上后, 再用两颗沉头螺钉M3-8固定塑料换挡拨片与碳纤维换挡拨片板

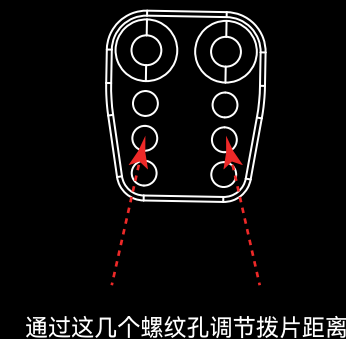
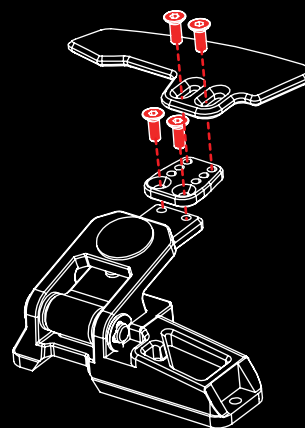

通过这几个螺纹孔调节拨片距离

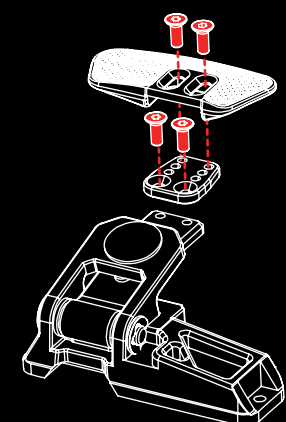

2.5 用铝制换挡拨片板时: 使用沉头螺钉M3-6固定

2.6 拧下固定装饰盖的M3螺钉, 取走装饰盖

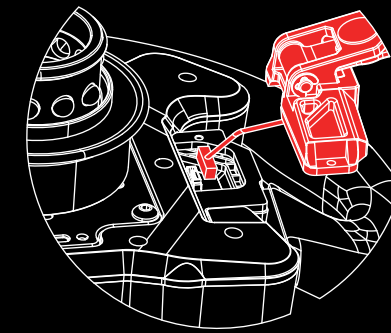

2.7 把单拨片组的端子线插到方向盘端子处

2.8 用拧下的M3螺钉固定单拨片组

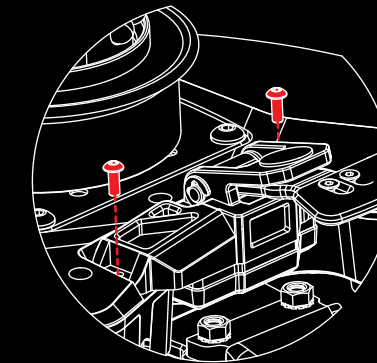

### 软件及应用



在PC端安装  
SimPro Manager  
进行设置



产品教程  
(更多相关资料扫码查看)



## Paddle Shifter Kit Single Paddle Edition Quick Guide

### 1.0 List of Accessories

- Spacer Column x4 (3.1x5x3mm)
- Spacer Column x4 (3.1x5x5mm)
- Countersunk Head Screw M3-6 x 6
- Countersunk Head Screw M3-8 x 10
- Countersunk Head Screw M3-12 x 6
- Allen Key x2 (2mm/2.5mm)



### 2.0 Installation

- 2.1 ① Injection-molded and carbon fiber paddles: Install with countersunk screws M3-8.
- ② Metal paddles: Install with countersunk screws M3-6.

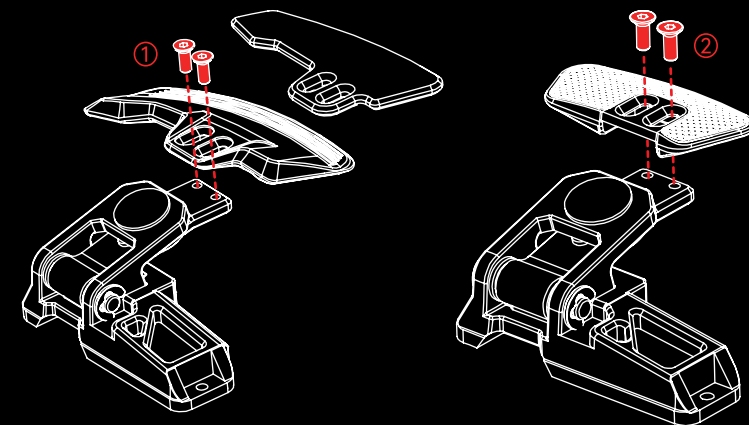

2.2 Based on the required distance, select a spacer column with a height of 3mm or 5mm. As shown in the diagram, secure it to the paddle using countersunk screws M3-12 (ensure the countersink side faces upward).

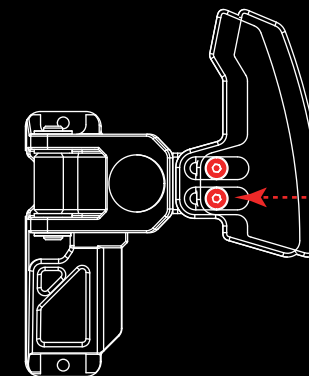
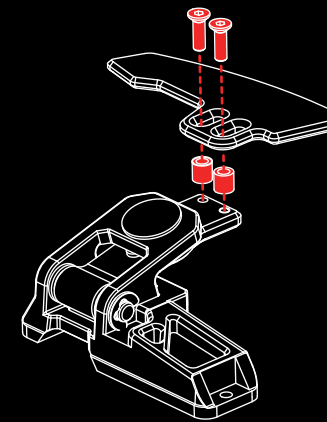

2.3 Adjust the paddle plate's distance by fine-tuning the two countersunk screws M3.

2.4 After installing the extender to the paddle with two countersunk screws M3-8, use two countersunk screws M3-8 to install the injection-molded or the carbon fiber paddle.

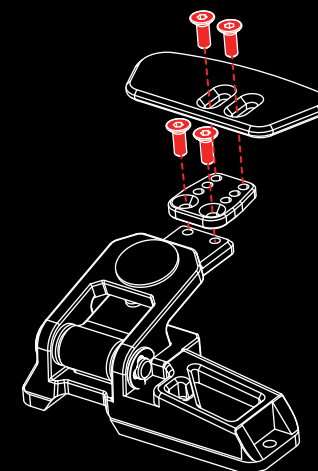

Use the threaded holes shown in the diagram to adjust the paddle distance.

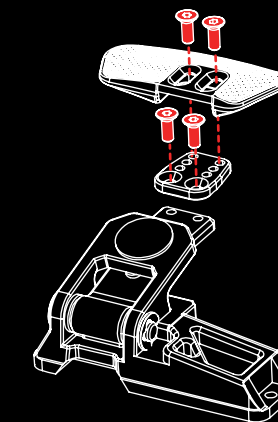

2.5 For metal paddles, use countersunk screws M3-6 to secure the paddle.

2.6 Unscrew the M3 screws securing the decorative cover and remove the cover.

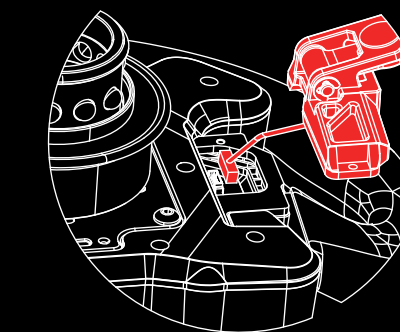
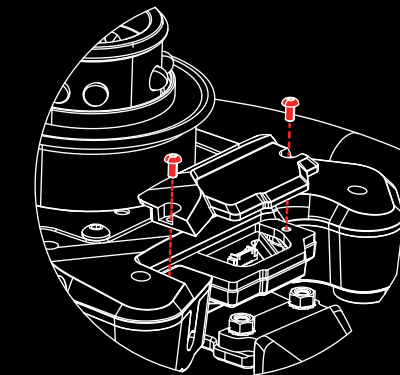

2.7 Plug the single-paddle assembly's cable into the connector on the steering wheel.

2.8 Use the removed M3 screws to secure the single-paddle assembly.

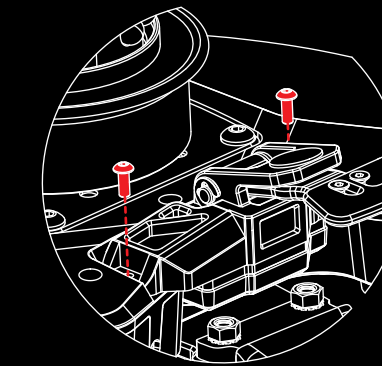

### Software & applications



Install SimPro Manager on PC to complete setup



Product Tutorial (Scan the QR code to view more)